

NAME Recardo House

STUDENT ID: UB73367SC082527

PROGRAM: Bachelors in Computer Engineering

COURSE NAME

Telecommunication and Networking Concentration

ATLANTIC INTERNATIONAL UNIVERSITY
August 2021

TABLE OF CONTENTS

INTRODUCTION	1
Telecommunication and Networking Concentration.....	1
Telecommunication :Smart Telecom Banking Card Systems.....	2
Understanding the Basic	3
Telecommunication.....	3
Parallel Serial Transmission.....	3
Channels and Facilites.....	4
Telecommunications Channel	6
Digital Analog Transmission.....	6
Bright Future with Fiber Optics.....	8
Fiber Selection.....	9
Bright Source Emitters and Detectors.....	10
Introduction to Switching Systems.....	11
Historical Development.....	12
Wireless Local Area Networks.....	14
Wireless Personal Area Network.....	15
Wireless Metropolitan Area Network.....	15
Teaching and Wi-Fi Networking Fundamentals.....	15
CONCLUSION	16
BLOGRAPHY	17

CHAPTER 1

Telecommunication and Networking Concentration

Overview:

INTRODUCTION

.....
The uses of telecommunications change work patterns, leisure time, health care, education, and industry.

The communications satellites generate energy from sunlight in space. New optical-fiber cables and semiconductor lasers work with to replace copper wire. Satellites and fibers transmit all information the human race possible use. There are no limits near in telecommunications and electronic technology.

A home ten or twenty years in the future, with television set can pick up international channels, also used conjunction with small keyboards provide multitude of communication services. The home has cabling under streets and new forms of radio provide manner of communication facilities.

(Vince, 1984)

Telecommunications: Smart Telecom Banking Card Systems

The microchips placed in plastic cards we carry in wallets, purses, and shirt pockets.

“Smart” cards (cards containing microchips can compute as hold data) a new frontier to designers of information systems, distributing processing power into hands of general public.

Bank issues card to account holder, personalizing it with individual’s account number and choice of personal identification number (PIN) inserting secret code word associated with the bank. The bank’s set monthly spending limit for card. Only bank official armed with bank’s code can make or change an authorization, only someone knowing card holder’s PIN can draw against it.

At point of sale, card plugged into a terminal has a separate customer keypad to protect privacy. Sale amount entered by sales clerk through main keyboard displayed on customer’s keypad, and if acceptable, and if acceptable, customer enters his PIN. If PIN agrees with stored inside the card if store’s terminal previously activate by legitimate store-owner’s card, transaction can proceed.

Terminal determines purchase amount, plus sum of pass month’s purchases read the customer’s card, exceed monthly authorization on the card. If enough credits left, transaction completed, transaction date and amount is written into customer’s card.

The date, amount, and purchaser’s account number entered into electronic memory to the store’s terminal. “Store and forward” terminal attachment mode, file is delivered---daily or any convenient interval---to store’s bank via dialed telephone line or physically transporting memory module to the bank. This transactions clears by bank electronic funds transfer (EFT) from purchaser’s account store’s account.

The transitional system is performs same functions as automatic teller machines (ATMs) and self-service travelers’ check dispensers, it differs fundamentally using computation capability and memory smart card in place of on-line capability of host

computer.

Understanding the Basics

The elements of basic telecom network. A network is arrangement of transmission, switching, signaling and terminal equipment. Transmission system provides electrical path information flow from one location to another. Switching includes identifying connecting transmission independent links from continuous path from location to another. Signaling supplying and interpreting supervisory address signals needed perform switching operation.

(Vince, 1984)

Telecommunications

Organizations with that have many branches or regional facilities have need to transmit and receive data frequently. The many use data communications system consisting wide variety components many variety of services. Combination depend upon merits and limitations various networks. One or more processors go through multiple front ends in one or more types of networks involving types of terminals. This type of network is called “distributed network.”

This electronic transmission encoded information one point to another requires physical elements, devise, and systems as standards and procedures. These basic elements and concepts help users with telecom services to advantage of communication systems now available.

Parallel and Serial Transmission

The communications with short distance between terminals (data input/output devices) and computers take place in variety of ways. Configurations, involve transmission of

data across multiple lines. Is known as parallel transmission. The transmitting one bit of seven-bit ASCII code character per line, would need seven lines. This transmission called parallel-by-bit serial-by-character (**Fig. 1.1**) This is used over short distances. Over long distances (involving miles) serial transmission involves only one data line.

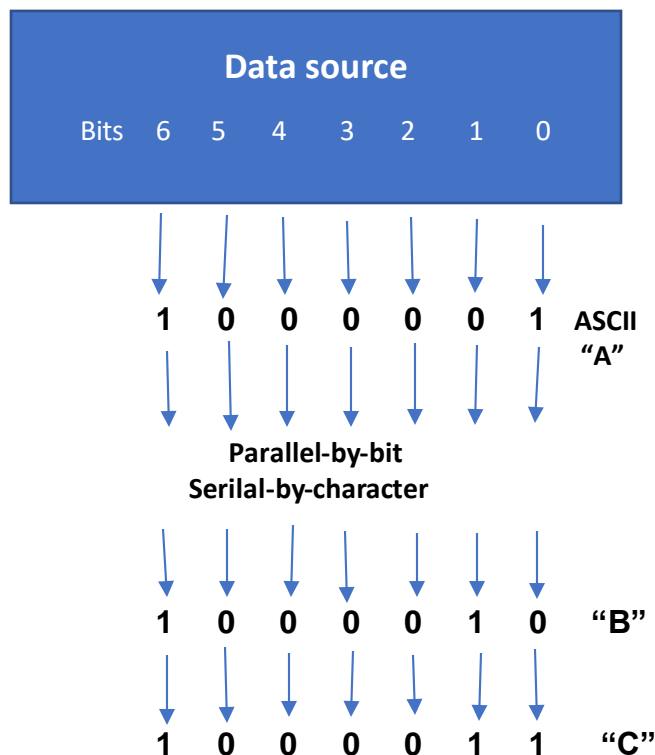

Figure 1.1 Parallel-by-bit and serial-by-character transmission.

To send data over a single line, bit transmitted in series. Is called (appropriately) serial transmission. It most widely used method transmitting data. In seven-bit ASCII, a "C" would appear in **Fig. 1.2**.

Channels and Facilities

The communication link or channel path for electrical transmission between two or more
(Vince, 1984)



Figure 1.2. Serial transmission is most often used.

stations or terminals. A single wire, group of wires, coaxial cable, a special part of radio frequency spectrum. The channel purpose is carry information from one location to another. Channels have limitations on information handling abilities, depending upon electrical and physical characteristics.

The three basic types of channels: simplex, half-duplex and full-duplex. As transmission between points A and B in **Fig 1.3**. Transmission from A to B only (not from B to A) requires simplex channel.

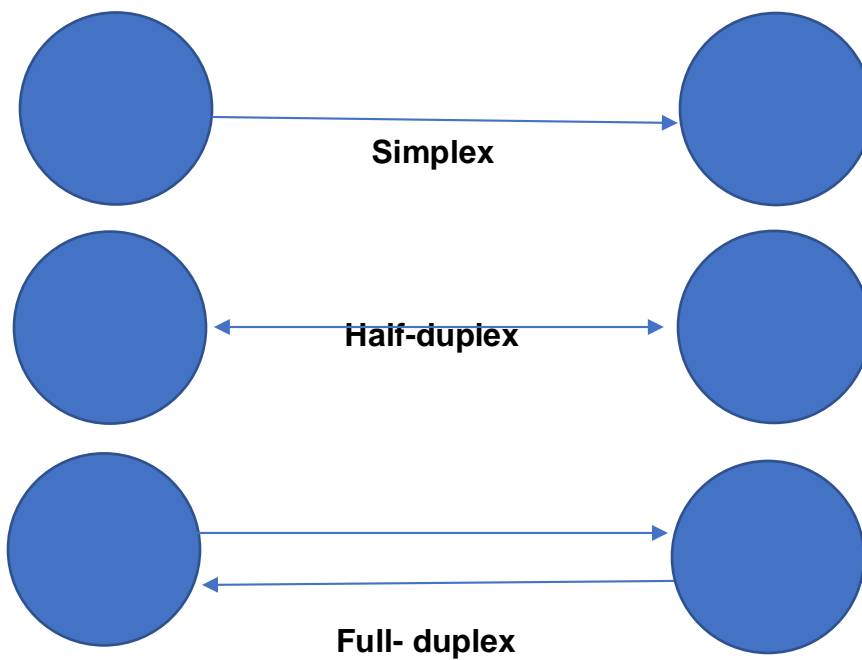

Figure 1.3. Types communications channels.

Simplex channels used loop mode configurations supermarket checkout terminals. Transmission from A to B and from B to A, not simultaneously, requires half-duplex channel. Four wires often used, two wire circuit support full-duplex communications frequency spectrum subdivided receive and transmit channels.

Telecommunications Channel

The direction of transmission, channel characterized by bandwidth. The greater the bandwidth assigned channel, higher the possible transmission speed. The speed usually measured terms of number of line signal elements per second, baud rate. If signal element represents one of two binary states, baud rate is equal to bit rate. When two states are represented, multilevel modulation, bit rate exceeds baud rate.

Digital versus Analog Transmission

Digital transmission applied to digital data or analog voice signals. Information send over communications channel a stream of pulses. Analog to digital conversion required, signal voltage values sampled and represented in binary format **Fig 1.4**. Transmitted over communication line distorted line capacitance, inductance and leakage. Longer line or faster plus rate, more difficult to interpret received signal. If noise and distortion threaten to destroy integrity of pulse stream, Pulses detected and regenerated. Regeneration process repeated properly, received signal be exact replica transmitted signal. Pulses can transmit over short distance using privately owned cable or wire pairs. Baseband transmission require line drivers and receivers on each end of line. The longer distance communication used digital transmission facilities common carriers. The analog transmission, continuous signal amplitudes or frequencies sent over the communication line.

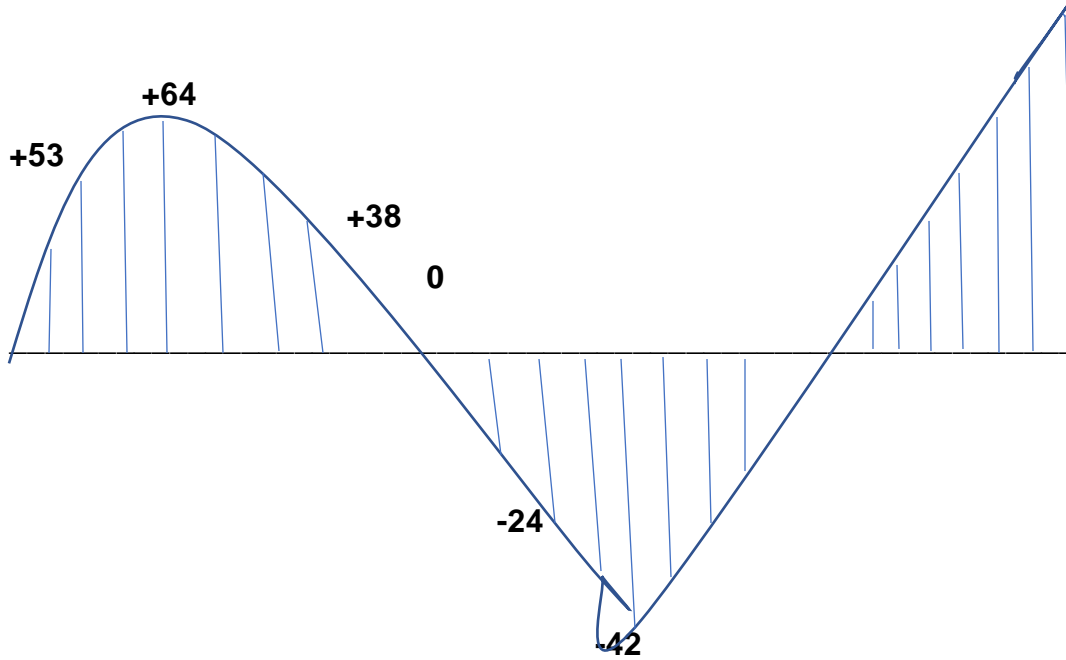

Sampled values In volts	Converted in binary code							
+53	1	0	1	1	0	1	0	1
+64	1	1	0	0	0	0	0	0
+38	1	0	1	0	0	1	1	0
0	1	0	0	0	0	0	0	0
-24	0	0	0	1	1	0	0	0
-42	0	0	1	0	1	0	1	0

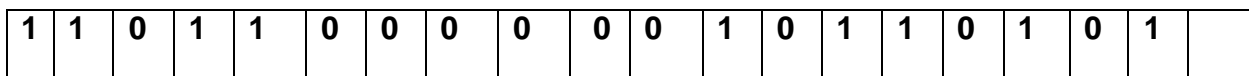

Figure 1.4 digital network analog signals convert into digital bits.

Bright Future with Fiber Optics

A fiber-optic cable carry 40,000 phone calls one time contrast to 20,000 calls with Copper cable. For sending super-quick light pulses is made of glass, clarity 1000 times greater than ordinary window glass. Fiber optics systems is effective method to transmit information look at (Table 1.1) below. Fiber optics provide advantage of light weight,

Table 1.1 Fiber Optics versus Conventional Cable

	SOLID COAX	FLAT RIBBON	CATV COAX	FIBER OPTIC
Physical	Small	Medium	Large	Small
Mechanical integrity	Good	Excellent	Excellent	Fair
Weight	Low	Moderate	Heavy	Low
Crosstalk immunity	Good	Good	Good	Excellent
Bandwidth	Good	Fair	Good	Excellent
EMI and noise immunity	Good	Fair	Good	Excellent

Small size, duration, nonconducting signal path which effect the electrical environment signal passes through. Frequency and distance limits fiber optic system is better than coaxial cable, twisted pair, or microwave waveguide systems.

The Fiber optic systems Figure 1.5 three components: light sources in transmitter, fiber cable, and photodetectors in receiver.

Fiber must be transparent that signal does not refreshed, amplified and repeated short distances. Photodetectors should be inexpensive, sensitive to proper frequencies, exhibit low noise levels.

(Vince, 1984)

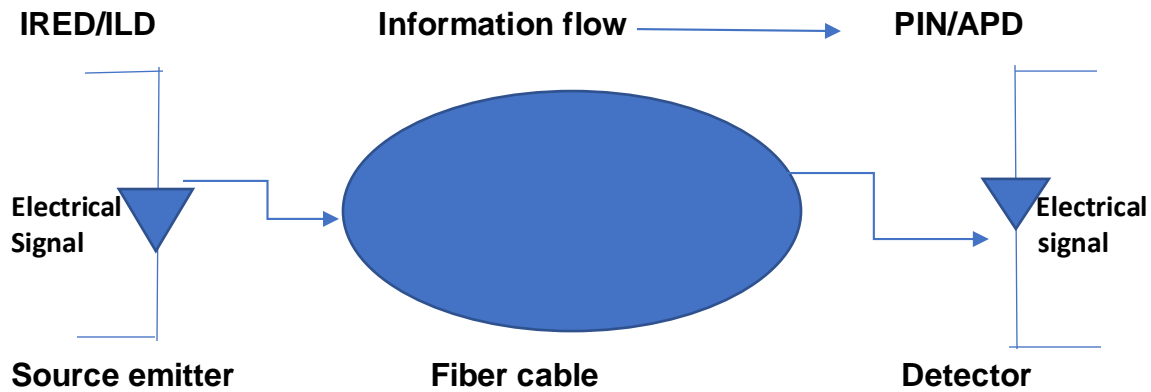

Figure 1.5 Elements of fiber optics systems

Fiber Selection

Fiber determines amount of power emitter or light sources place in fiber attenuation of light power travels down fiber. The step index fiber has abrupt change index refraction. A graded index fiber, index refraction changes gradually too high to lower value position radially from the center, causes rays gradually bend back towards the center, the reflecting, keep rays traveling along fiber the same velocity. The velocity property in multimode fiber gives graded index fiber higher bandwidth-distance characteristics. Highest bandwidth-distance fibers are designed to operate like microwave waveguide. (Fig 1.6)

Velocity of light in fiber, as medium, varies it wavelength—longer wavelength, greater velocity. The emits light over a range of wavelengths, shorter wavelengths light trail behind longer, broadening the signal. The diameter of fiber less than two wavelengths, one mode propagated, is called single mode fiber. This diameter, fiber optics resemble the transmission of microwaves.

Single mode fibers have greater bandwidth than multimode fibers why signal is not subjected modal dispersion. Less power coupled of the severe constraint imposed the single characteristic angle. Development single-mode fiber through 1980's expected

new application for fiber optics technology allow transmission signal greater distances without repeaters.

Cross section

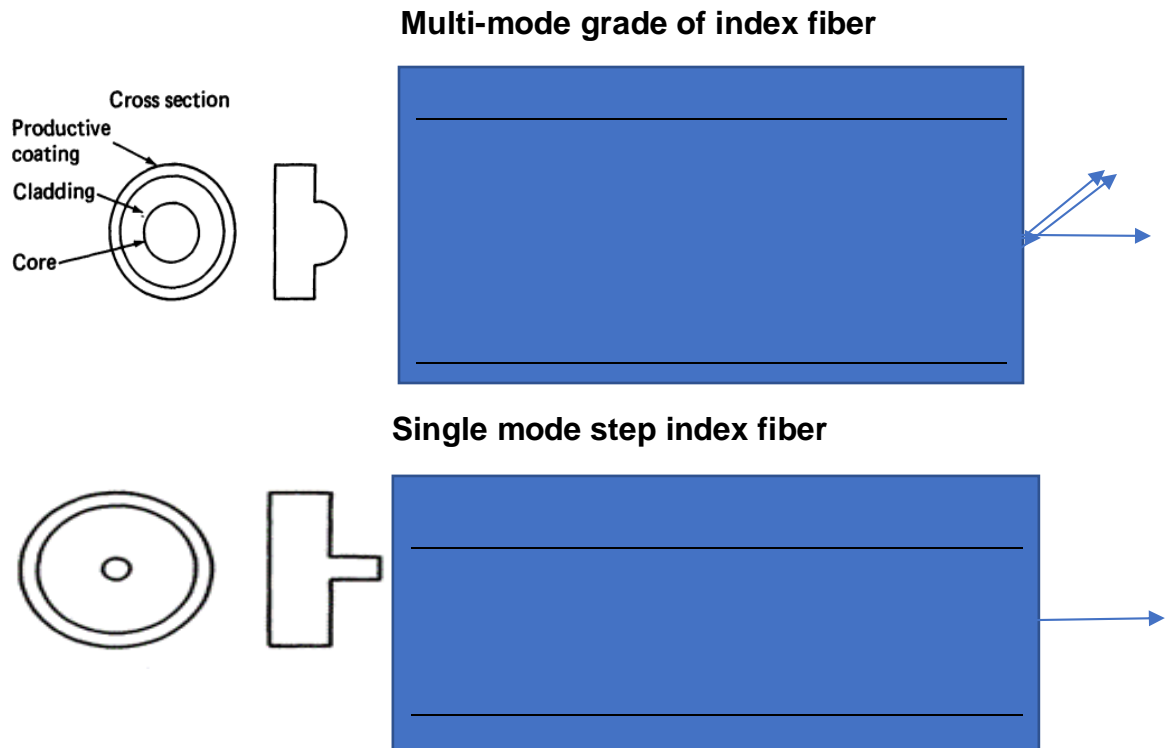

Figure 1.6 Signal propagation modes for fiber types

Light Source Emitters and Detectors

Emitter transforms electrical signal into light signal coupled to fiber and transmitted. Popular light used are infrared emitting diodes (IRED) and injection laser diodes (ILD).

Laser diodes is small, powerful with high speed capability. It's well suited digital transmission systems. It's highly emitters and substantially power coupled if injection laser diodes is used.

The light emitting diodes suited ideally to analog applications. Leading to large mismatch coupled into fibers with small cones acceptance. It's difficult to achieve good

power couplings most LED into diameter fibers.

Fiber optic receivers, detectors, photodiodes convert light into electrical current. Photodiodes are small, inexpensive, don't need much power drive them. Two photodiodes common today: Pin diode and avalanche diodes, APD. PIN diode is simple and inexpensive type photodiode, and adequate a wide range applications. This sensitive more expensive, type is avalanche diode (APD). Also less interference with APD with PIN diode, noise less interference with APD than PIN diode, allows higher transmission speed to the link.

(Vince, 1984)

Introduction to Switching Systems

Telecommunication networks carry information signals among entities, geographically apart. The entity may be computer or human being, teleprinter, facsimile machine, data terminal so on. The entities involved information transfer which form telephone conversation (telephone) of file transfer between two computer or message transfer between two terminals.

(P, 2006)

The rapid traffic and untargeted growth telecommunication, cyberspace becomes fabric of life. As we anticipate growth of new services and more users. A genuine need for advanced methodology supporting analysis and design telecommunication architectures. Telecommunication has growth at rate recent years and undoubtedly continue now.

Communications switching system enables universal connectivity. Universal connectivity is entity in part of the world communicate with other entity in another part of world. Telecommunication acts as substitute increasingly expensive physical transportation.

Telecommunication links and switching designed for voice communication. The

attachments/equipments, used to transmit data networks, with large communication satellites, small, cheap antennas.

Historical Development

By 1800's scientists developed ways generate transmit electricity. The 1819, oersted discovered magnetism and electricity. In 1834, Gauss and Weber wired over the roofs Gottingen and make telegraph system.

Samuel F.B Morse's developed first work in telecommunication. Morse developed code telegraphy 1837. 1844, 40 mile telegraph line setup between Baltimore and Washington by F.B. Morse.

Elisha Gray and Alexander Graham Bell works and filed paper related to telephony . Early stages development of telecommunication were due to A.G. Bell, G. Marconi and C.E. Shannon. Year 1876, Bell invented telephone system. In 1897 Marconi patented a Wireless telephone system. Teletypewriter service was initialed in 1931.

Electromechanical switching system replaced by computer controlled switching systems referred stored program control (SPC). SPC, switching controlled by software program. First computer switch controlled introduced 1960. In 1965, computer controlled switching used transistors printed circuit technology. In 1965 switching based on microprocessors.

The computers switching led designation "electronic" switching system (ESS) or Electronic automatic exchange (EAX). Year 1970, first electronic switching system No. 1 ESS or No 1 EAX was introduced. Digital electronic switching system introduced into U.S. Public network in 1976 with AT & T's No. 4 ESS digital toll switch. In mid-1980's interoffice transmission environment change to almost exclusively digital. **Fig 1.7** show various telephone networks.

(P, 2006)

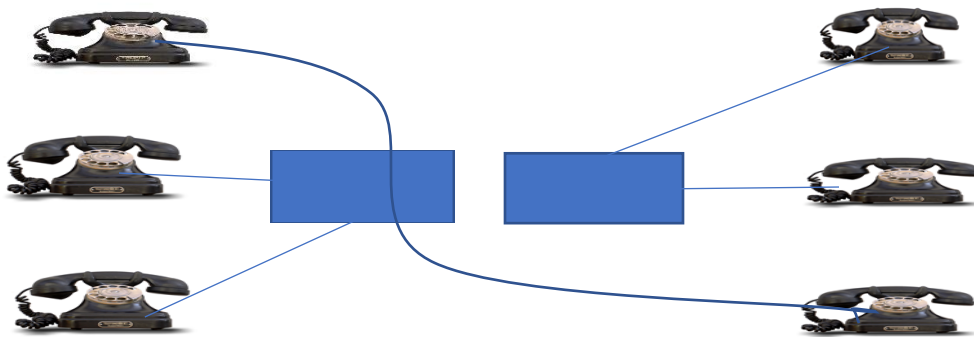

(a) Telephone network around 1890

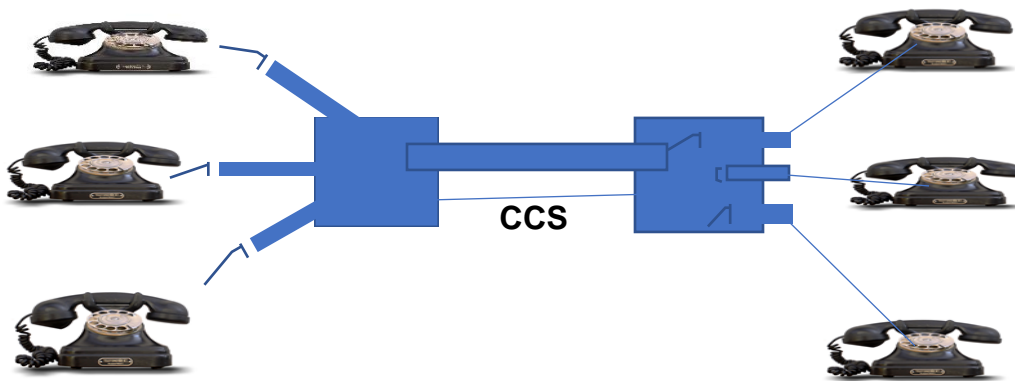

(b) Telephone network around 1988

Telecommunication Switching and Networks

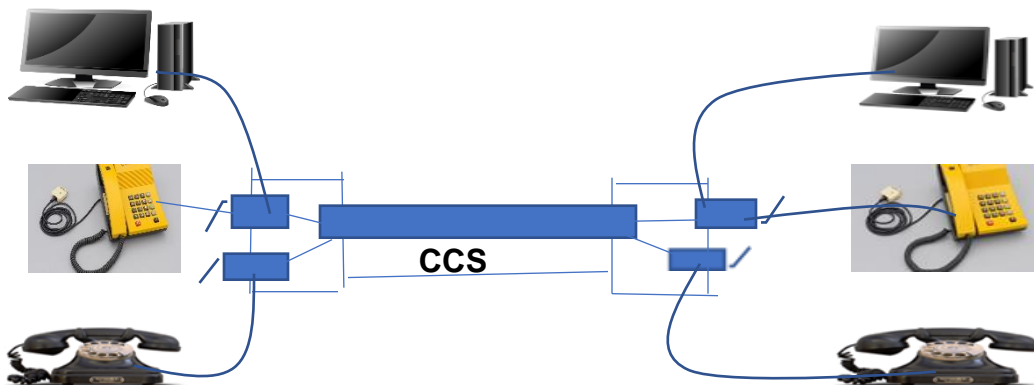

(c) Telephone network after 1990 with ISDN

Figure 1.7 Various telephone networks. (P, 2006)

Wireless Local Area Networks

The wireless local area networks (WLAN) replacing wire within homes and office rapidly. The wireless LANs base on the IEEE 802.11 standard (Gast, 2005; Wi-Fi Web site) They referred to Wi-Fi networks. The Internet combined increased of portable, laptop computers contributed rapidness of WLANs. The widespread adaptation are low cost and ease of installation. (Jairo, 2009)

The original 802.11 standard, adopted 1997, data rates up 2 Mbps. Higher data rate to 802.11, referred as 802.11a, 802.11b, and 802.11g, emerged later. The 802.11b system operates in 2.4 GHz band provides data rates up 11 Mbps. The drawbacks 802.11b is limited capacity due to bandwidth availability 2.4 GHz band. The 2.4 GHz is “crowd” with device like as cordless phones, microwaves, and Bluetooth. The drawbacks mitigated with emergence 802.11a devices, operate in 5 GHz band data rate to 54 Mbps. Wider bandwidth available 5 GHz band using 802.11a based WLANs office environments. Fig 1.8 shows Wireless LAN and wired LAN networks

WiFi proven way providing reliable building wireless access. Cellular phone the manufactures launching dual mode GSM/WiFi devices made and receive calls both cellular network and enterprise WLAN.

European WiFi counterpart Hiper-LAN (high performance radio local area network), Standardized by European Telecommunications Standard Institute (ETSI). HiperLANs physical layer Wi-Fi used mainly in Europe.

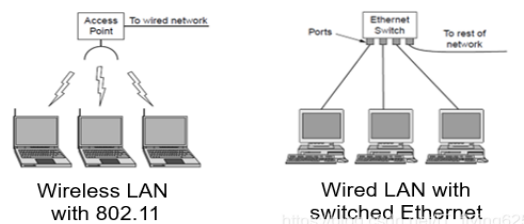

Figure 1.8 Wireless LAN and wired LAN network.

Wireless Personal Area Networks

Wireless personal area networks (WPANs) designed replace the wires connect devices to another (like headphone cable, printer cables, cables run personal computers mouse, cable run for set-top boxes). Bluetooth (Bluetooth Web site,) is widely embraced WPAN standard. Operates in 2.4 GHz unlicensed band provides short-range communication nominal range of 10 meters. Laptops and cell phones support Bluetooth connections. Manufacturers, like Acura and BMW, installing Bluetooth in cars. Bluetooth devices consume extremely low power provide communication data rates to 2.1 Mbps.

The Zigbee (ZipBee Web Site) another competing technology wireless PAN. ZigBee devices expected cheaper and simpler Bluetooth devices. The applications ZigBee include general-purpose, inexpensive, self-organizing mesh network share medical devices, smoke and intruder alarms, building and home automation.

(Jairo, 2009)

Wireless Metropolitan Area Network

Wireless metropolitan Area Networks (WMAN) provide broadband access to Internet anytime anywhere. The wireless MAN technology based on the IEEE 802.16 standard, referred as WiMAX networks (Ohrtman, 2005; WiMAX Forum Web site). WiMAX is third-generation cellular system provide broadband connections over long distance, is a fourth-generation technology. Third-generation systems support both circuit and packet switching, fourth-generation systems support packet switching only. First-generation WiMAX expected support data rates up to 40 Mbps per channel vehicular speeds. High radio metropolitan area network (HiperMAN) European alternative to WiMAX. Korea adopted WiMAX as wireless broadband (WiBro) as wireless MAN standard.

Teaching and Learning Wi-Fi Networking Fundamentals

The Wi-Fi networks (called IEEE 802.11b) gain popularity, in business and home

networking applications. The growing of mobile equipment, this likely continue in the future. Important that students of information and telecommunication technologies cover fundamentals wireless networking technologies as their curriculum.

The complexity of underlying concepts wireless networking can intimidate students. The can discourage students learning in-depth of wireless technology. To overcome the problems teachers can provide hands-on introduction to Wi-Fi networking. Tutorial can guide learners on how to set up Wi-Fi networks using few computing resources. Students are encouraged gain a hands-on learning experience in setting up Wi-Fi networks.

(Jairo, 2009)

CONCLUSION

Wireless LANs provide users with information within organization without the restrictions inherent physical cable connections. The wireless LANs allow access from unreachable network cables. The basic building block of wireless network basic service set (BSS). BSS consists of set fixed or mobile Wi-Fi stations. Simplest network configuration is independent BSS (IBSS), is an ad hoc network of two or more stations without any structure other than peer-to-peer cooperation.

BLIOGRAPHY

Jairo, G. (2009). *Selected Reading on Telecommunications and Networking*. New York: Information Science Reference IGI Global.

P, G. (2006). *Telecommunication Swithcing and Networks*. New Delhi: New Age Internation Ltd.

Vince, C. (1984). *TELECOMMUNICATIONS: Equipment Fundamentals and Network Structures*. New York: Van Nostrand Reinhold Company Inc.

